

KEYKING DPU3000POE Series

Manual



Keyking Group

Catalog

Chapter 1	KEYKING Overview	3
1.1	Basic Composition of Access Control System.....	3
1.2	Working Principle	5
Chapter 2	PCB Layouts & Features	6
2.1	DPU3012POE	7
2.2	DPU3022POE	8
2.3	DPU3024POE	9
2.4	DPU3044POE	10
2.5	DPU3048POE	11
2.6	DIO3168P	12
2.7	Features	13
2.8	Specification	14
Chapter 3	Connections & Installations	15
3.1	Power Supply	15
3.2	Connections	16
3.3	Wiegand Interface Wiring.....	18
3.4	RS485 Reader Wiring	20
3.5	Lock Wiring	21
3.6	Sensor Wiring	22
3.7	Controller DIP Switch.....	23
3.8	Installation of Controller and Reader.....	24
3.9	Cable Specifications.....	25
Chapter 4	System Operation	27
4.1	Controller ID Setting.....	27
4.2	Controller IP Configuration	27
4.3	Security Check	27
4.4	Controller Light Condition.....	27
4.5	Buzzer & LED Instructions.....	28
Chapter 5	Trouble Shooting	29

Chapter 1 KEYKING Overview

1.1 Basic Composition of Access Control System

KEYKING access control system includes DPU1000, DPU3000, DPU3000POE and DGS500 series. In this manual, we focus on the DPU3000POE access control system.

Model Identification:

DPU 30 2 4 POE

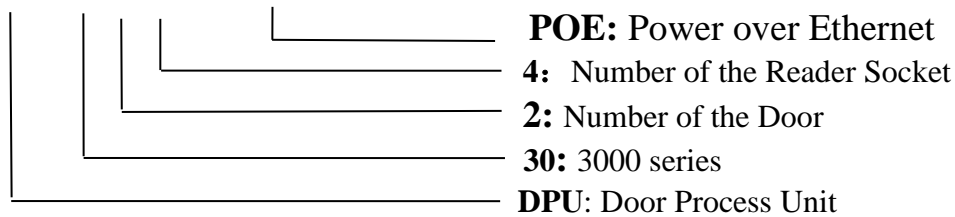

DPU3000POE access control system consists of DPU3012POE, DPU3022POE, DPU3024POE, DPU3044POE, DPU3048POE, Reader, Lock, Proximity Card、Sphinx4.4 software and some product accessories.

System Diagram:

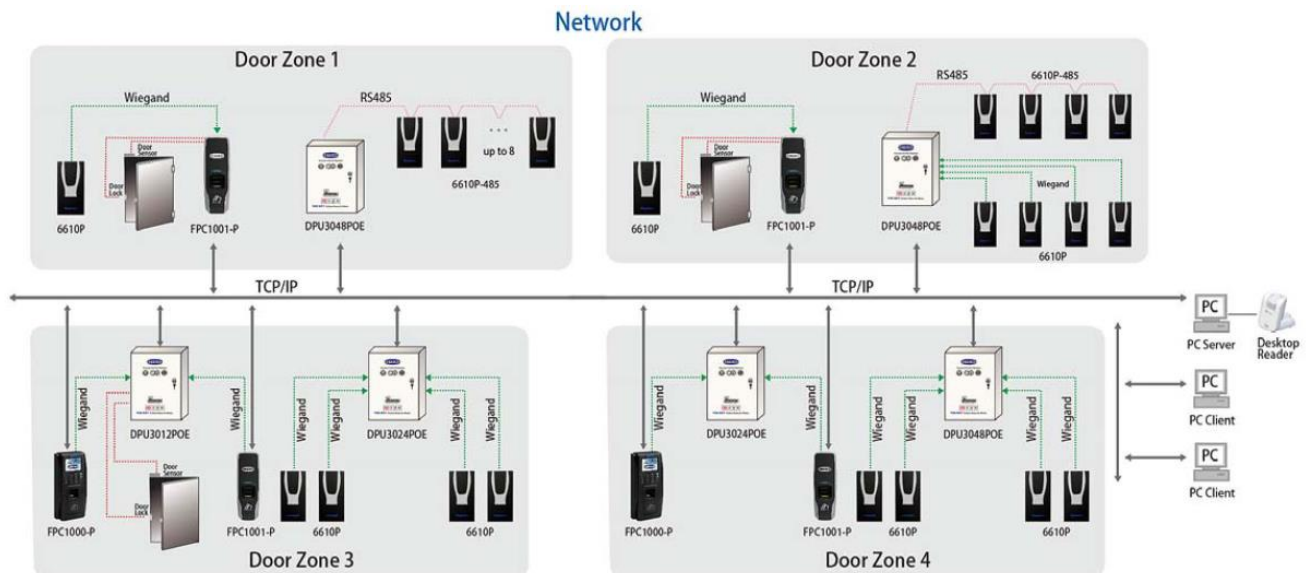

Figure 1-1-1 DPU3000POE series connection diagram

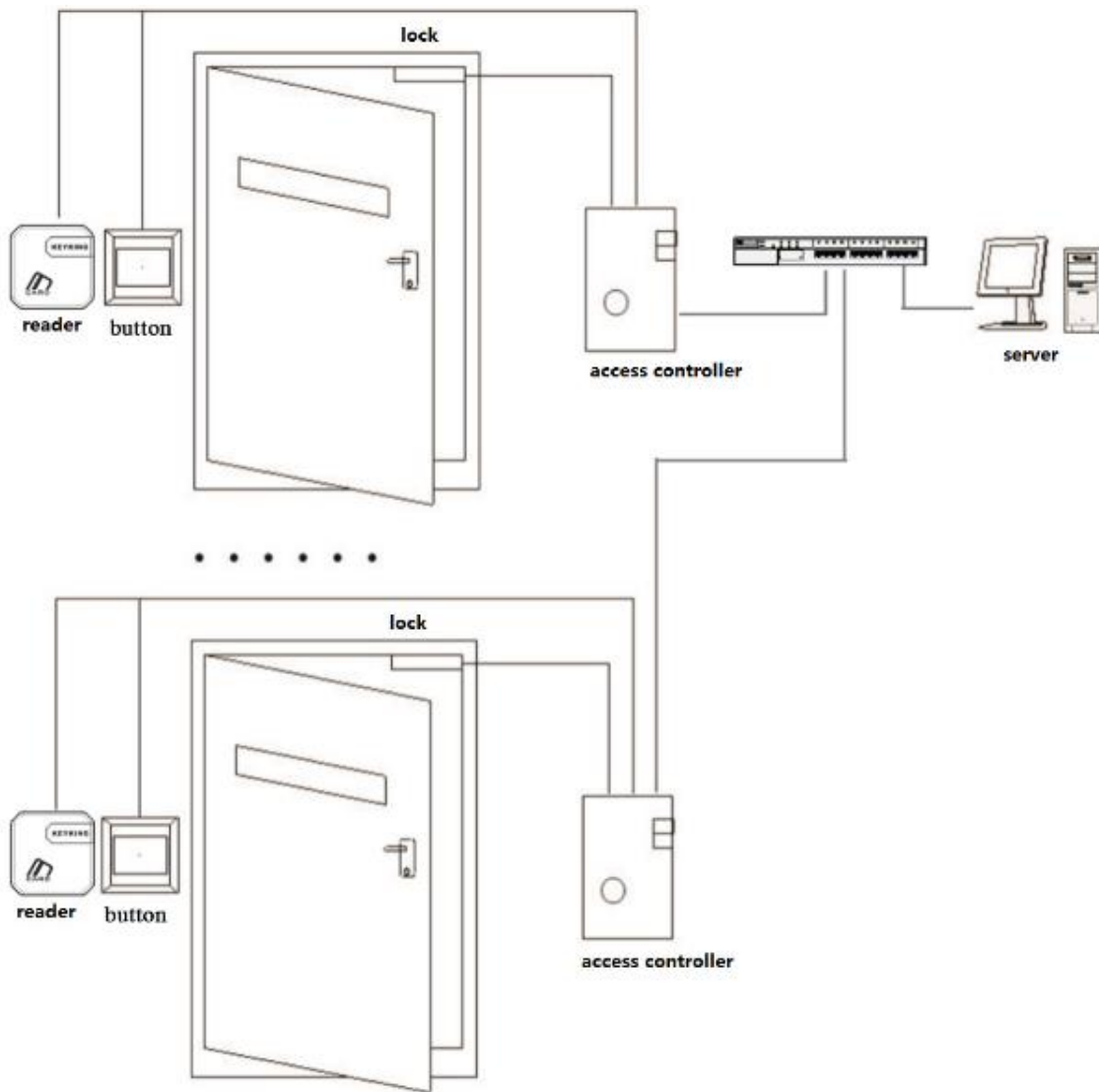

Figure 1-1-2

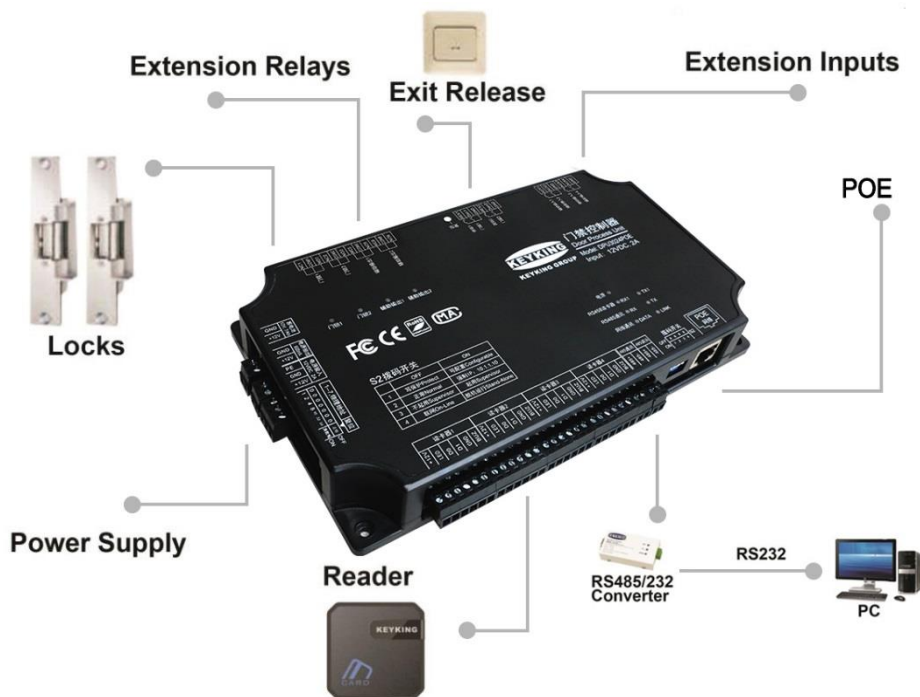

Figure 1-1-3

1.2 Working Principle

Inductive technology, or radio frequency identification (RFID), is a method of reading information on a card without requiring direct contact between the card and the card reader.

The use of inductive card reader, will no longer wear out due to contact friction caused by the card and card reading device, and then there is no need to bring the card into the hole in the card or magnetic card slot, only can be shaking in the reader range. Refer to figure 1-1-4.

In induction technology, the reader continuously sends an electromagnetic field of 125kHz through its inner coil, called the “excitation signal”.

When a card in the card reader range, card coils produce weak current by the “excitation signal” induction, as the power of a small integrated circuit in the card, The circuit stores a unique digital identification number (ID) entered at the time of manufacture, which is transmitted back from the card through a 62.5 kHz modulated signal back to the reader, which is called a “receive signal”.

The reader will return the received radio signals to the controller, the controller processing, checking, and converting into digital signals, then it sends the digital controller identification number (ID) to the microprocessor controller, which make access decision.

There is a kind of induction key, it similar to the induction card, but it's size is smaller than the general induction card, the internal coil is also smaller, so the corresponding card reader only half of the general induction card. According to the same principle, the larger the number of coils in the card or card reader, the longer the reader distance is.

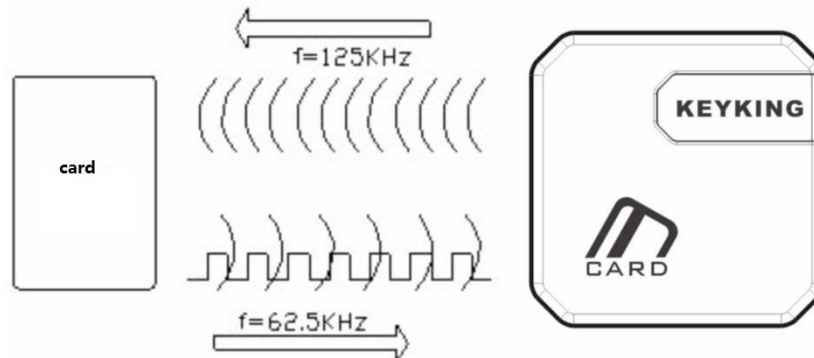

Figure 1-1-4

Chapter 2 PCB Layouts & Features

DPU3000POE series are new design and state-of-the-art 1\2\4\8 doors access controllers made by KEYKING, it's the most effective solution for today's intelligent building. Perfectly designed to work with the Sphinx Software. The DPU3000POE series allow wide range of security levels, according to the security level required at the location of the DPU3000POE, which can be used to control and record employee entry\exit inside or outside of restricted areas. The recorded data may be automatically fed into Sphinx security software.

Each type of DPU3000POE controller can work independently, both offline and online. When working offline, it will store all the security definitions, as well as card holders and transactions information.

DPU3000POE Order Information:

Model		DPU3012POE	DPU3022POE	DPU3024POE	DPU3044POE	DPU3048POE
Doors		1 (double)	2 (single)	2 (double)	4 (single)	4 (double)
Reader Sockets	Wiegand	2	2	4	4	4
	RS485	2	2	4	4	8
Aux-Input		4	4	4	4	4

Aux-Output	2	2	2	2	2
------------	---	---	---	---	---

2.1 DPU3012POE

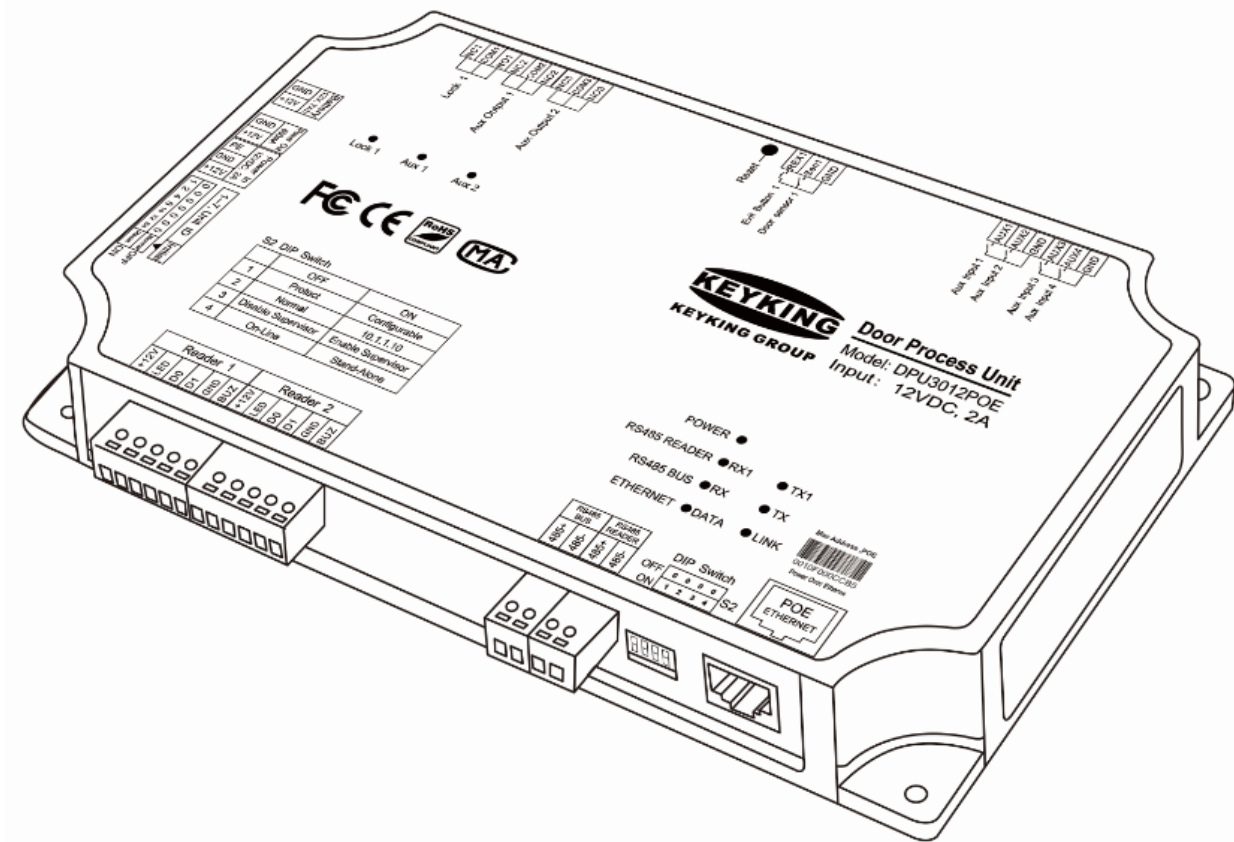

Figure 2-1-1 DPU3012POE controller

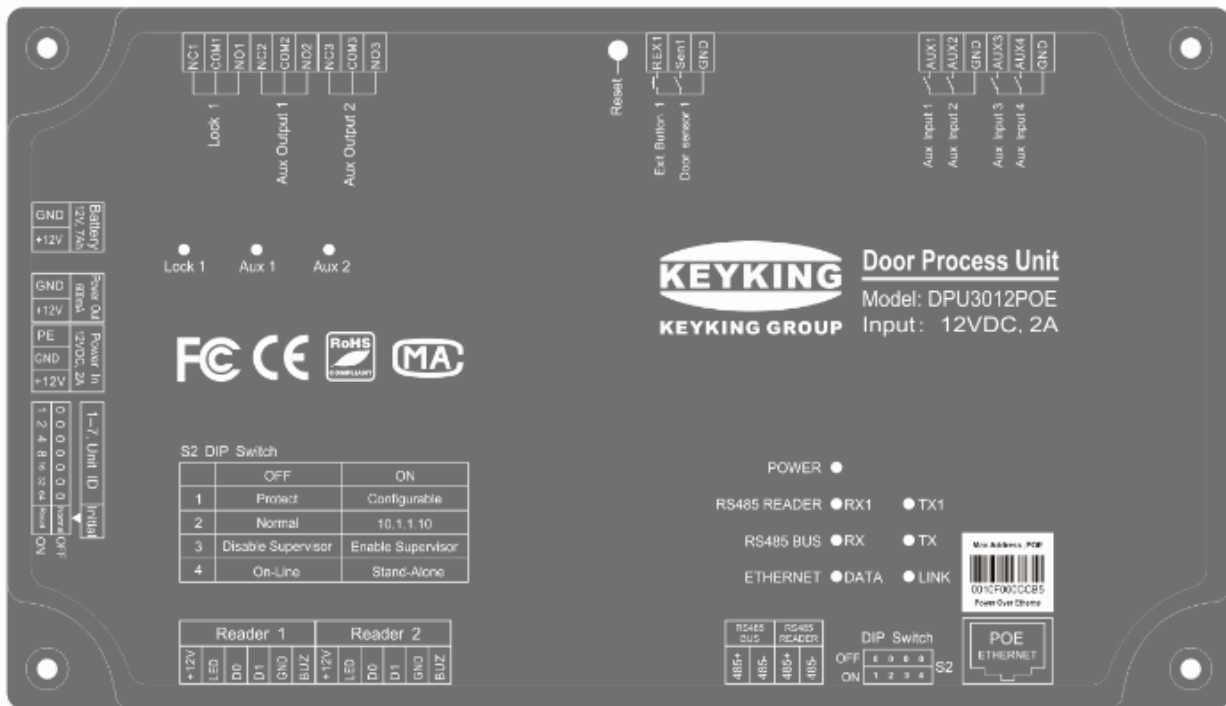

Figure 2-1-2 DPU3012POE wiring Schematic diagram

2.2 DPU3022POE

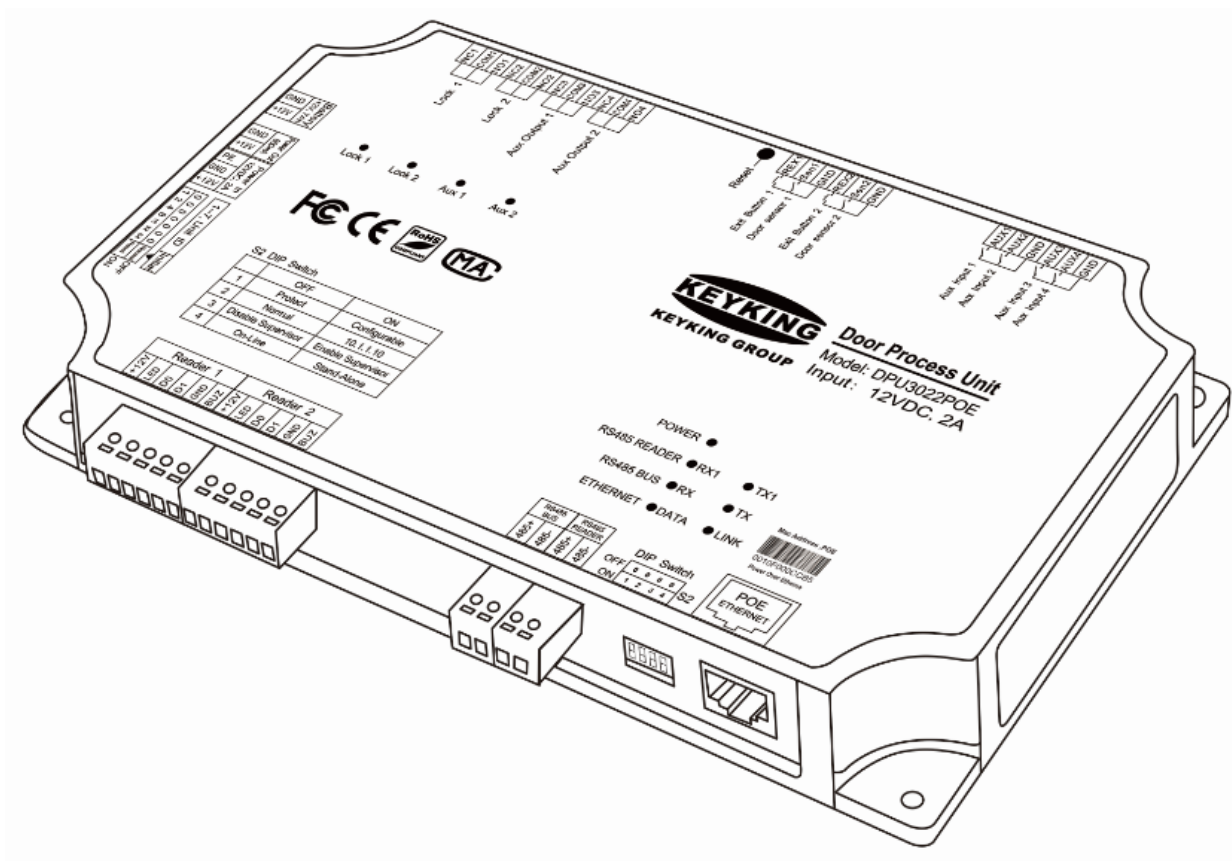

Figure 2-2-1 DPU3022POE controller

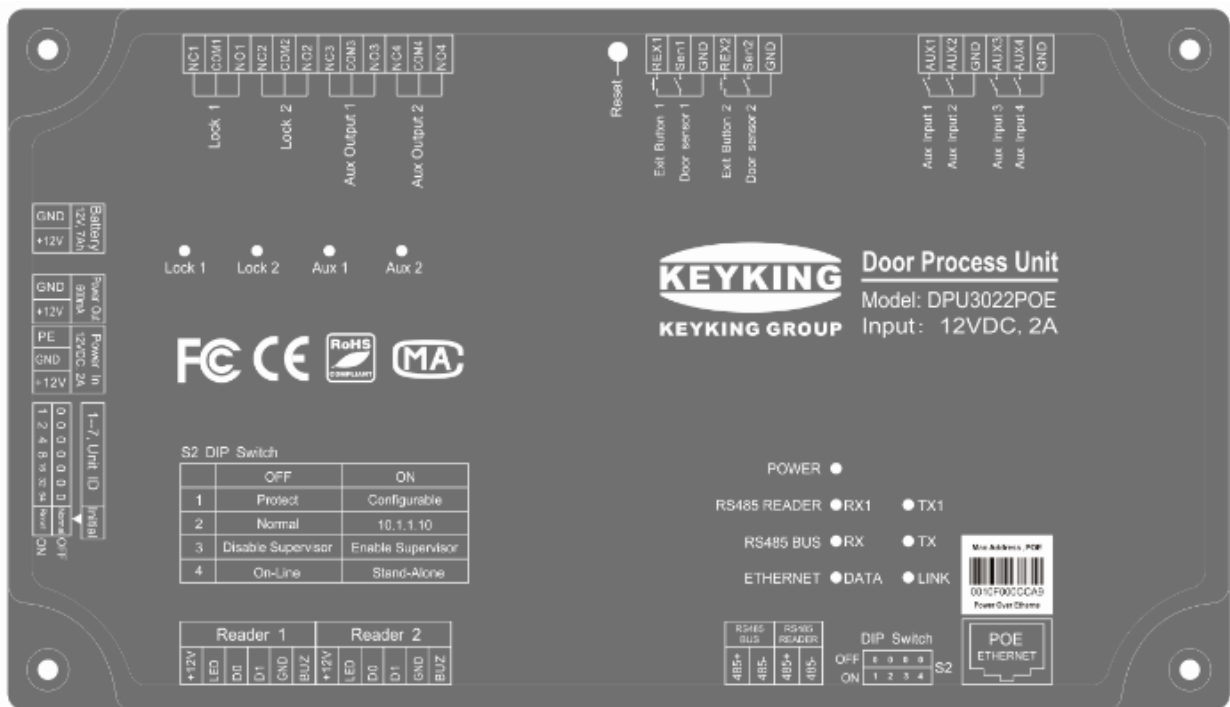

Figure 2-2-2 DPU3022POE wiring Schematic diagram

2.3 DPU3024POE

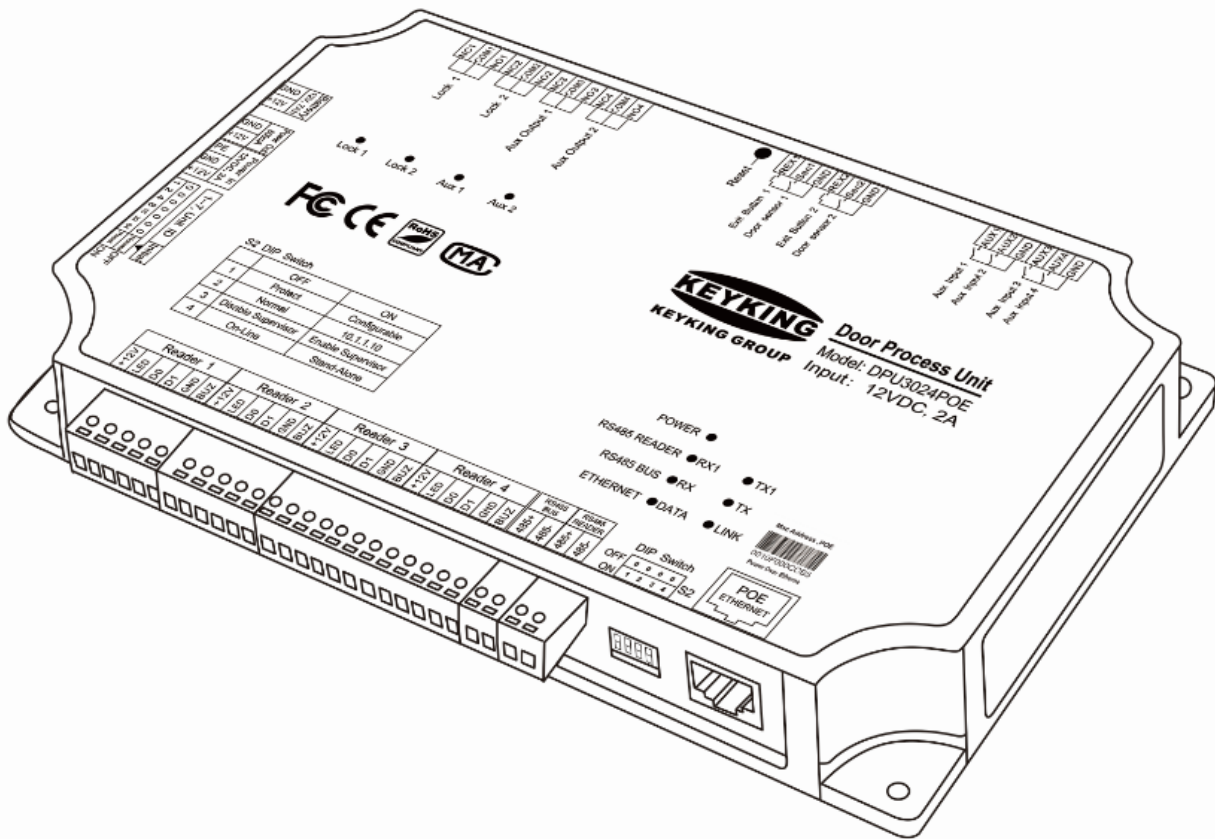

Figure 2-3-1 DPU3024POE controller

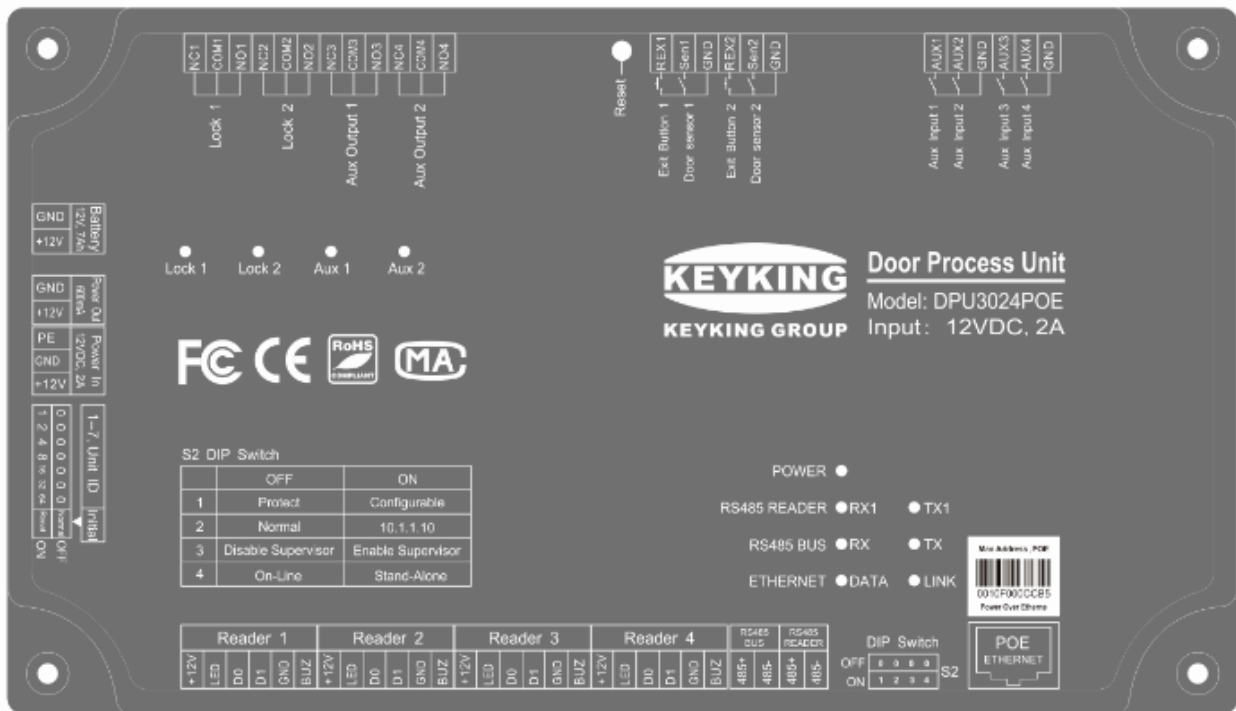

Figure 2-3-2 DPU3024POE wiring Schematic diagram

2.4 DPU3044POE

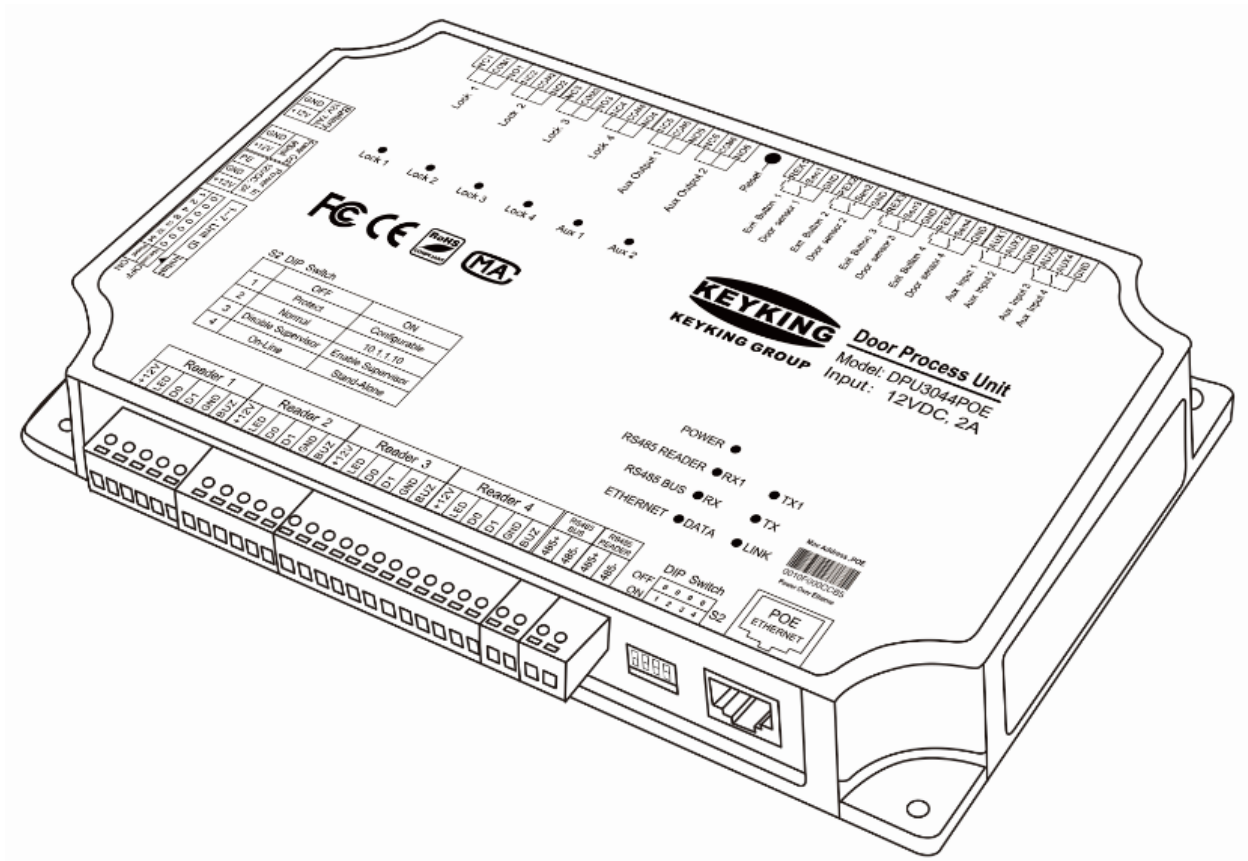

Figure 2-4-1 DPU3044POE controller

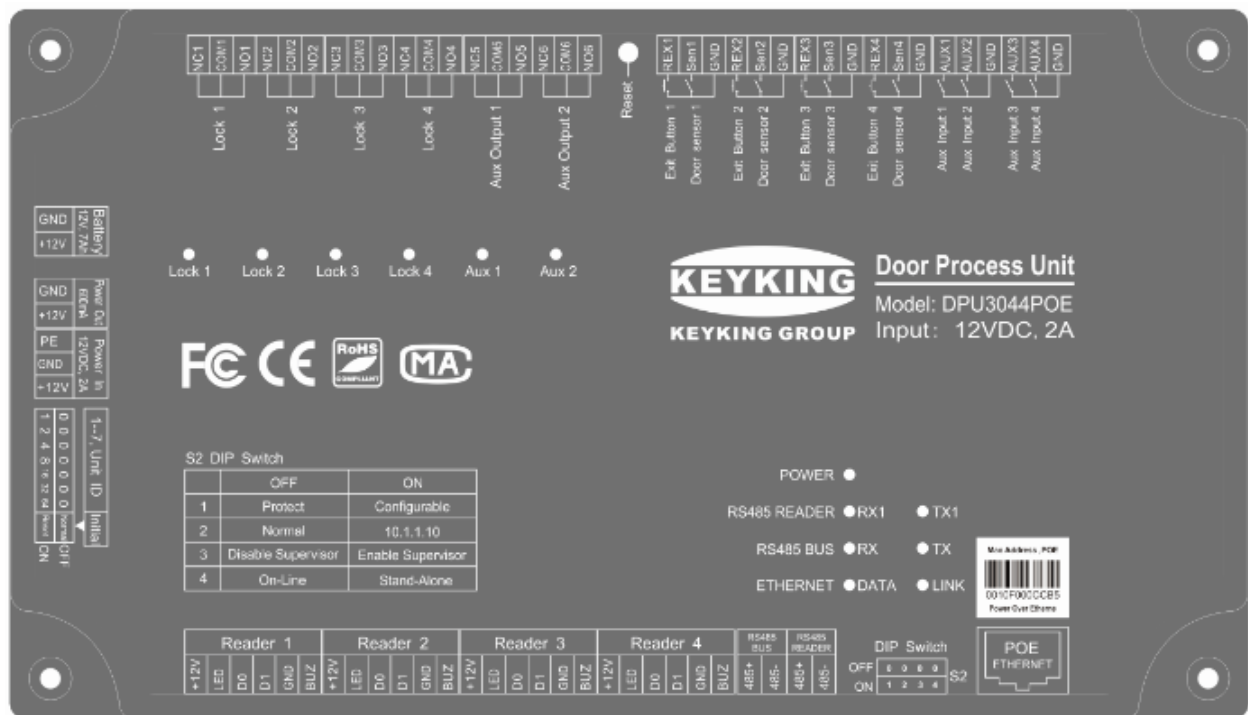

Figure 2-4-2 DPU3044POE wiring Schematic diagram

2.5 DPU3048POE

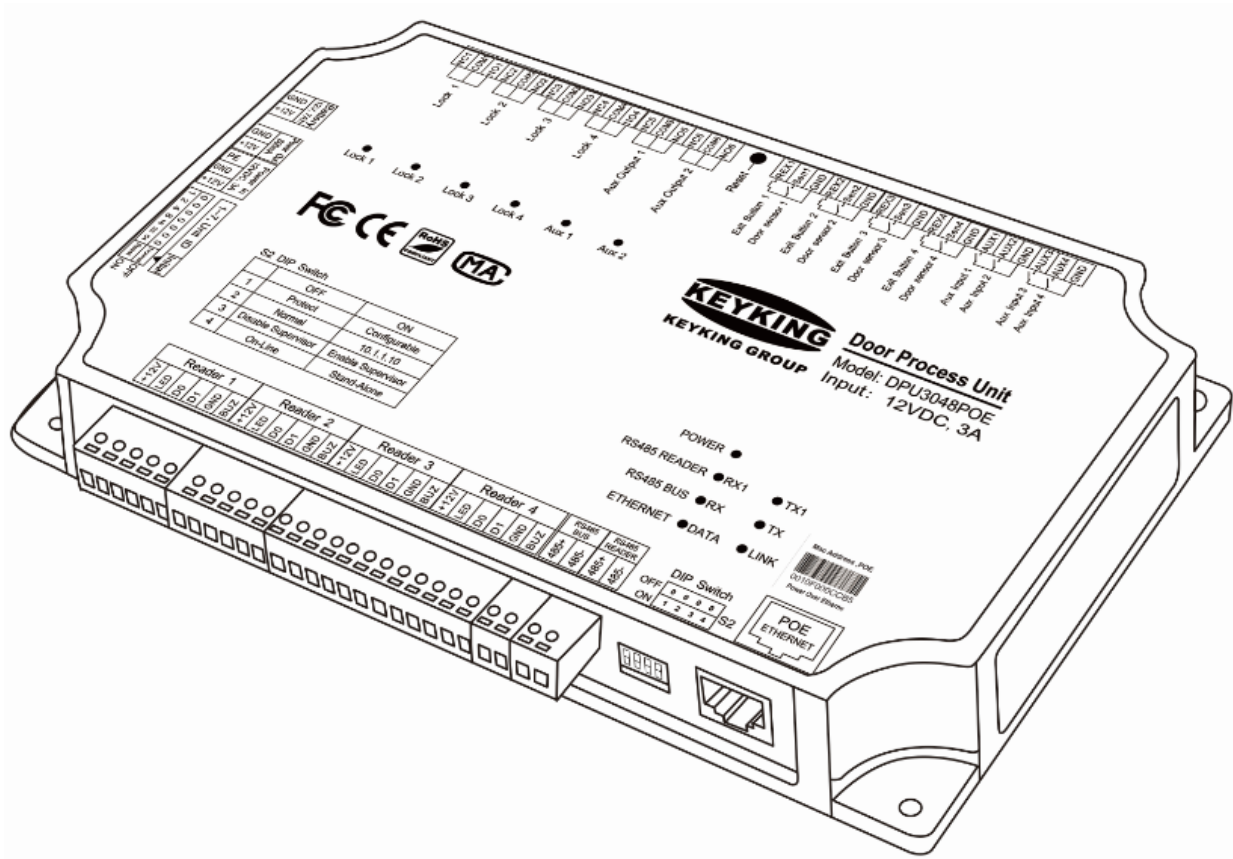

Figure 2-5-1 DPU3048POE controller

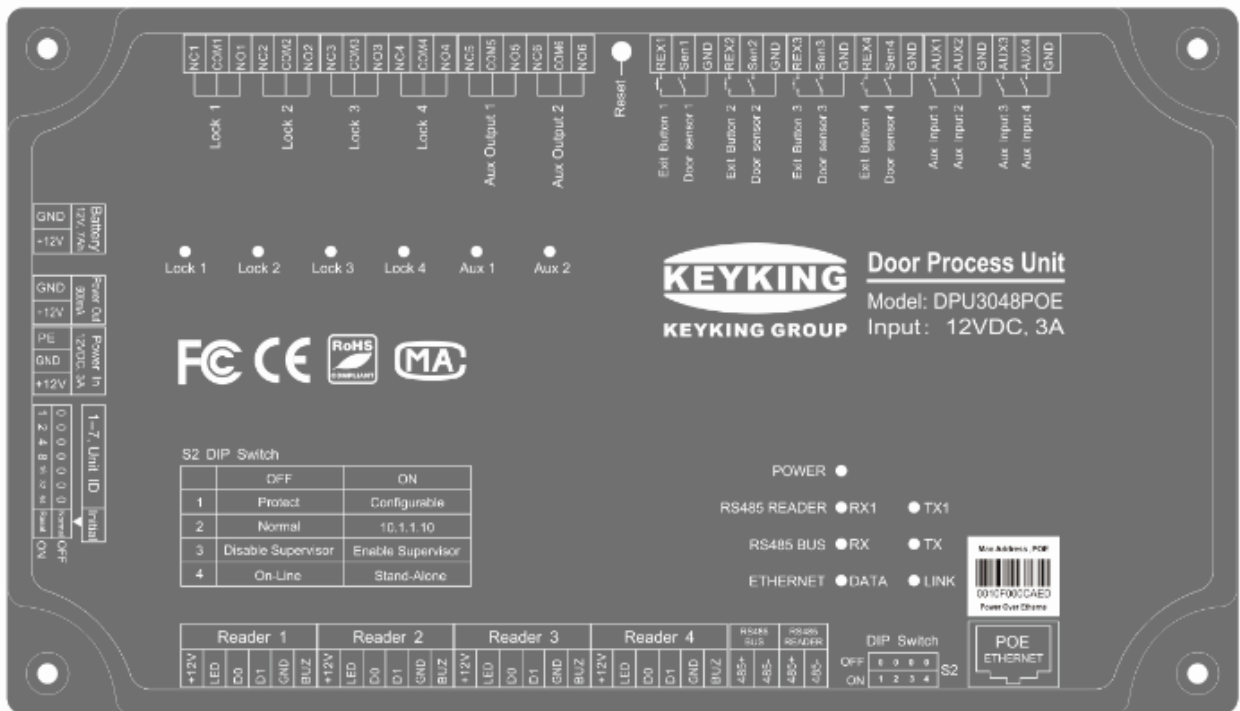

Figure 2-5-2 DPU3088POE wiring Schematic diagram

2.6 DIO3168P

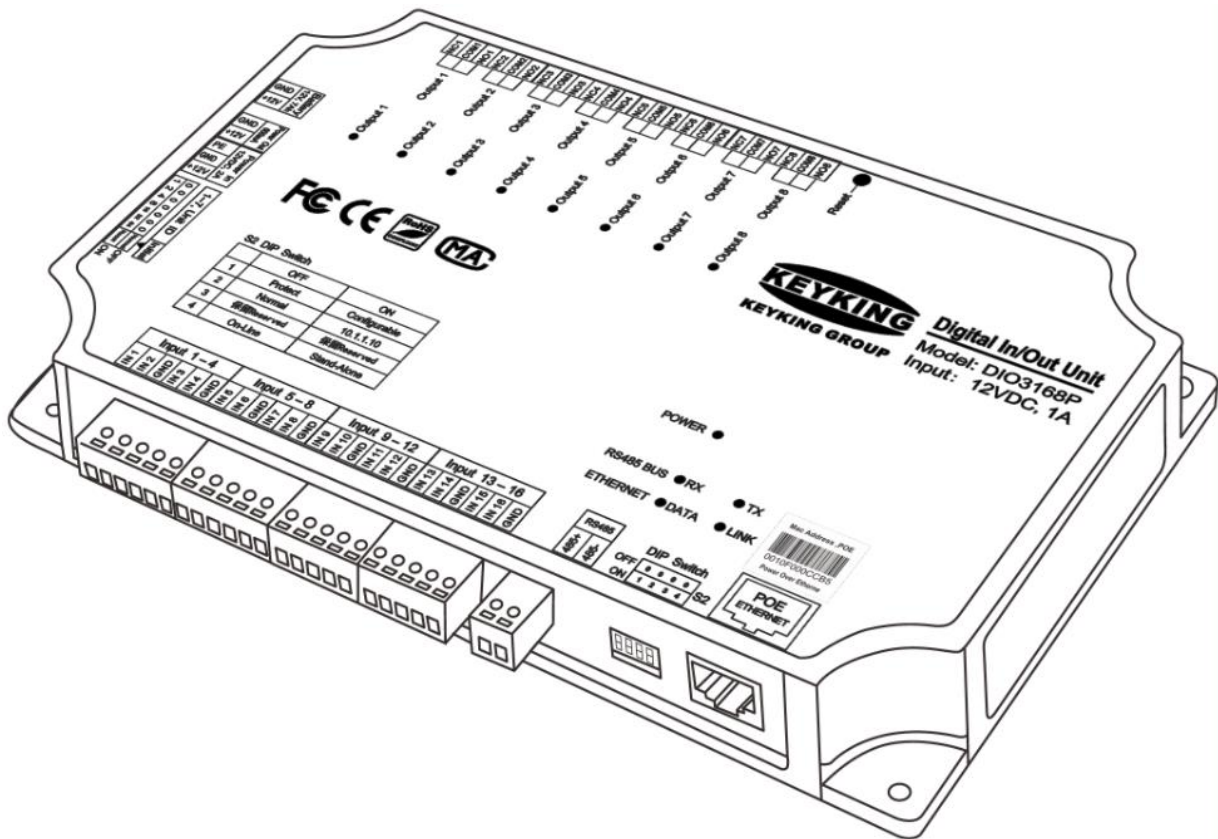

Figure 2-6-1 DIO3168P controller

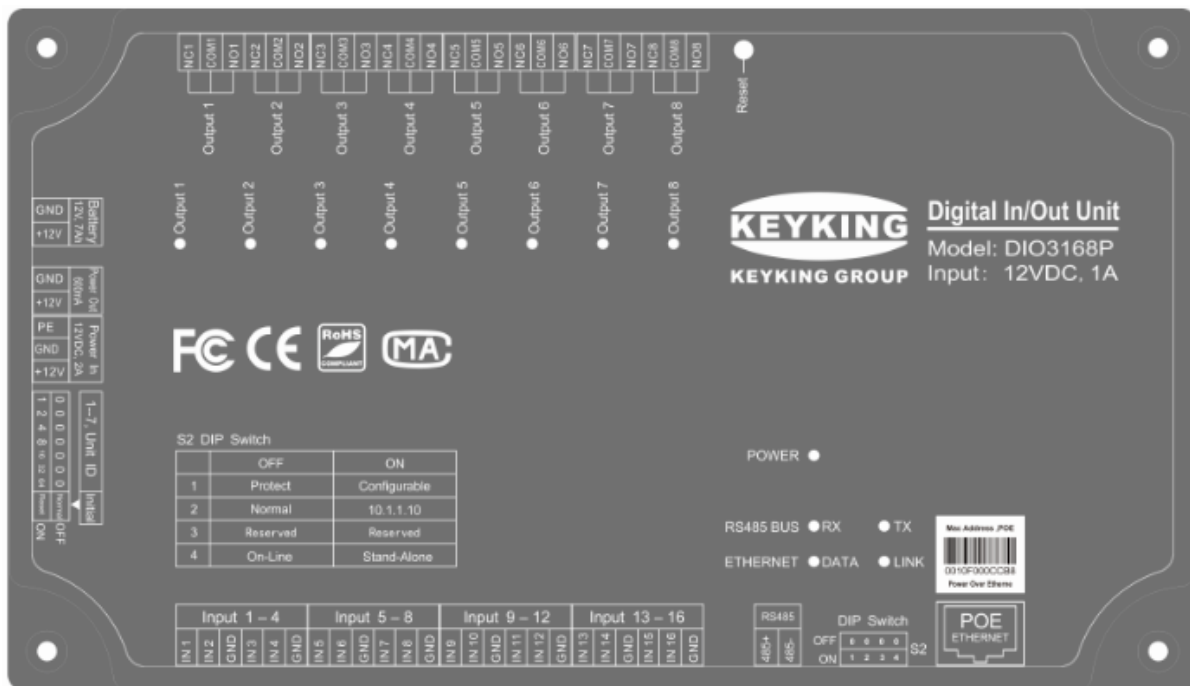

Figure 2-6-2 DIO3168P wiring Schematic diagram

2.7 Features



Flexible Configuration

- composition: DPU3012POE, DPU3024POE, DPU3048POE
- consist of 1\2\4 doors controller, and can be used freely.



Ultrafast Speed

- 100,000 card holder, can be recognized in 0.1s



Compatible with all Wiegand reader formats

- compatible with all Wiegand reader formats from 24 to 72 bits
- The card number is valid for 8 bytes



RS485 Reader

- compatible with RS485 reader, Convenient wiring and saving resources



POE Power Supply

- provide power to controller and reader via CAT5\6 cable, also supply power for lock which needs small electric current.



Flow Control

- flexible and configurable flow control, can be set between all input and output.



Confirmed by Center

- practical and high security of door opened by “confirmed by center” function, suitable for the vault, the prison, etc....

- The valid card also needs to be confirmed by central staff before opening the door.



Twins Card Mode

- only master & slave card can open the door by swiping them together.
- each card can only select one master card



Group Card Mode

- door can be opened if staff in each group is in the same location and has completed a valid card within a short period of time

- Up to 4 groups, each one can be set to different groups



Online \ Offline Mode

- online: connect to PC server, offline: work as a standalone, disconnect to PC.

2.8 Specification

CPU	32 bits ARM@ Cortex-M4 Processor
Card Holder	100,000 users
Transactions	200,000
Communication	TCP\IP 100M based
PoE	803.11af
Reader	Compatible with all Wiegand reader formats: -fingerprint readers - Biometric devices -EM\Mifare reader Compatible with RS485 card reader - Known protocol OSDP reader -485 reader
Number of Reader	-connect with 4 weigand reader and 4 RS485 reader -connect with 8 RS485 card reader also - Can be mixed use, add up to 8 card reader
AUX-Input	4
AUX-Output	2
Temperature	-20°C~65°C
Power Supply	POE Power Supply; Operating Voltage: 12VDC Operating \leq 0.3A (controller) , \leq 3A (reader connected)
Dimension (mm)	W138*H244*D33 (controller) W384*H403*D72 (box)
Authentication	CE, FCC, RoHS, MA

Chapter 3 Connections & Installations

This chapter covers the system wiring required to install and connect a SECUSYS controller including the power supply connection, communication connections, reader connections, lock connections, inputs/outputs and cable specifications.

3.1 Power Supply

3.1.1 220VAC supply

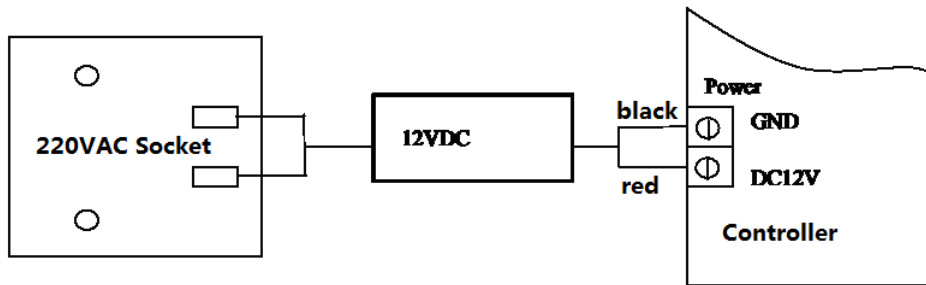

Power:

No.	Controller socket		Identification	Color	Remark
1	Power In	PE	Protection	Yellow	
2		GND	Ground	Black	
3		DC 12V	12VDC	Red	

3.1.2 POE Power Supply

The POE provides power and data from a single point, using Power over Ethernet over a single Cat-5 cable. The nine fast Ethernet ports can be used for any 10\100 Mbps link and four of these ports can supply industry-standard IEEE802.3af power. Advances auto-sensing algorithm gives power only to IEEE802.3af end devices, so no need to worry about damaging proprietary POE or non-POE equipment.



Notes:

- 220VAC power and POE power supply, two choose one, do not use at the same time.
- When using POE power supply, total current \leq 1000mA, output current \leq 600Ma
- please check the working current carefully to avoid the shortage of power supply when connecting the reader.
- When using a magnetic lock, please do not take electricity from the controller in case the power supply is insufficient.
- When using POE power supply, you can connect the battery to the controller.

3.1.3 SMPS1260 Power Supply

The SMPS1260 is a heavy duty Switch Mode Power Supply with a 110-123V input. It has 2 outputs, a 12V DC 6 Amp primary output and a secondary 12V DC battery charging output.

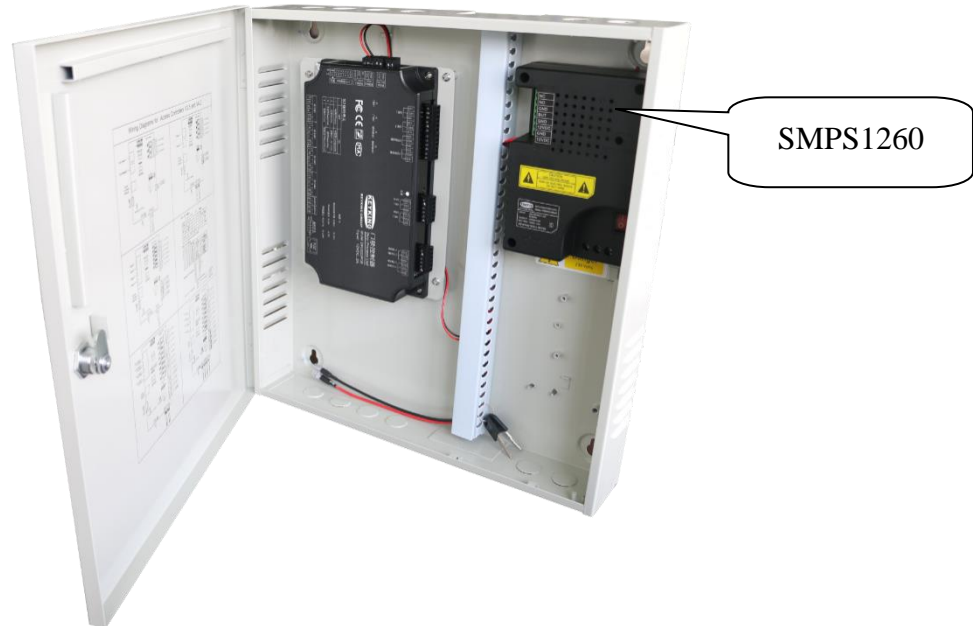

Figure 3-1-1

3.2 Connections

3.2.1 RS485 Interface Notes

In RS485 mode the DPU3000POE series access controllers use the half-duplex RS485 protocol. This protocol has a maximum distance of 1200 meters (4000 feet) so the distance between the first and last device on a RS485 network can be no greater than 4000 feet without some sort of amplification. All controllers in the same RS-485 line must be connected in a daisy chain or multi dropped configuration

Before wiring, please make sure to disconnect the power supply, otherwise the device may be damage seriously.

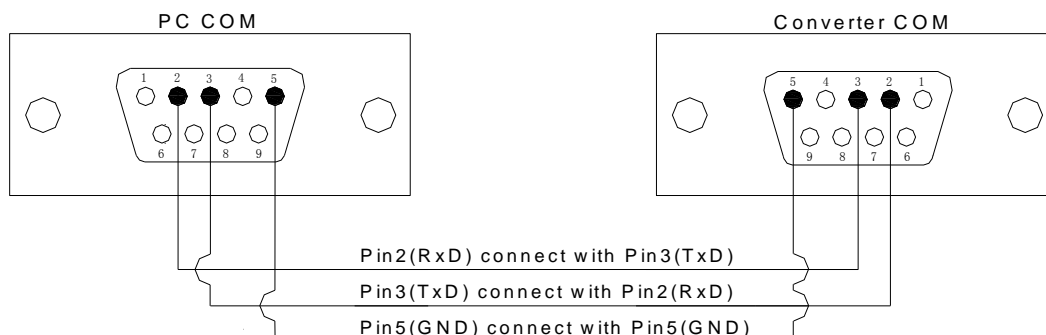

The RS-485 cable must not be connected at any points other than the controller(s) and the RS-485 interface. Do not connect any RS-485 wires to the GND of the controller. If a shielded cable is used then the shield must be connected to a strong ground or earth at a single point only in order to avoid earth loops and data corruption. Where the RS-485 shielded cable connects to a controller the shield between the IN cable and the OUT cable should be looped together but insulated from ground. Note that if a RS-232 to RS-485 converter is being used to connect to a desktop PC then the RS-485 line could, but not always, be earthed via the computer.

The last controller on a RS-485 LAN must be terminated using a 120 ohm termination resistor. Note that the diagram shows an external termination resistor however a jumper inserted on the pins located adjacent to the RS-232/485 terminal block on the controller inserts an internal termination resistor in the circuit. Only one controller per RS-485 line needs to be terminated.

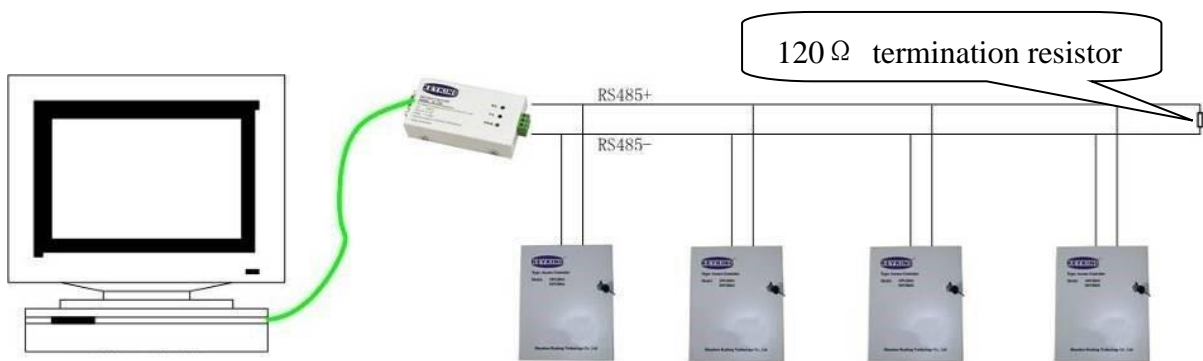

3.2.2 TCP/IP Communication wiring

DPU3000POE series use the onboard 100MHz TCP\IP port on the controller to connect to a TCP\IP based network. This method uses one IP address per controller.

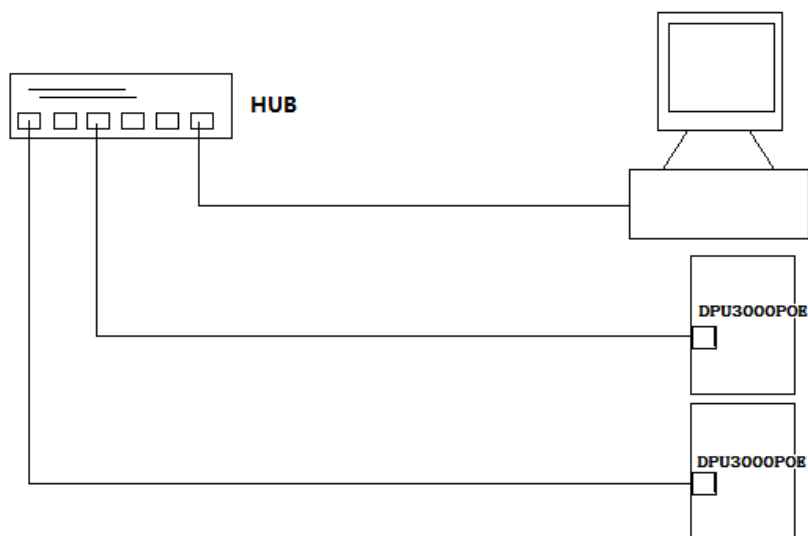

3.2.3 Description of the RJ45 Sequence

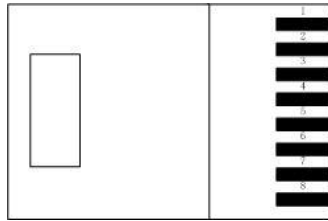

RJ45	Identification
1	TX+
2	TX-
3	RX+
6	RX-

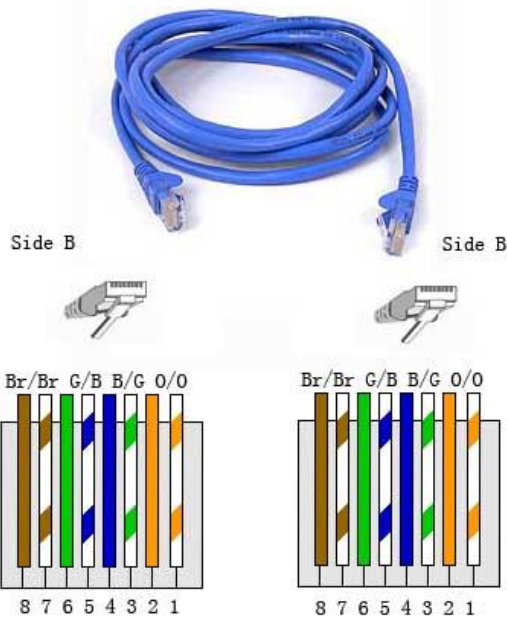

3.3 Wiegand Interface Wiring

Each card reader socket of the controller has a current protector Fuse, the operating current is greater than 135mA, the protector acts and cuts off power fail automatically; when card reader current is less than 135mA, the protector back to normal mode.

The following table list the correct PIN connections for the most common type of Wiegand devices.

NO.	function	Keyking Reader	
		Color	Identification
1	+12V	Red	7—14VDC
2	LED	Blue	Green LED
3	Data 0	Green	Data0
4	Data 1	White	Data1
5	GND	Black	GND
6	Buz	Yellow	BUZ

3.3.1 Reader Connection (wire)

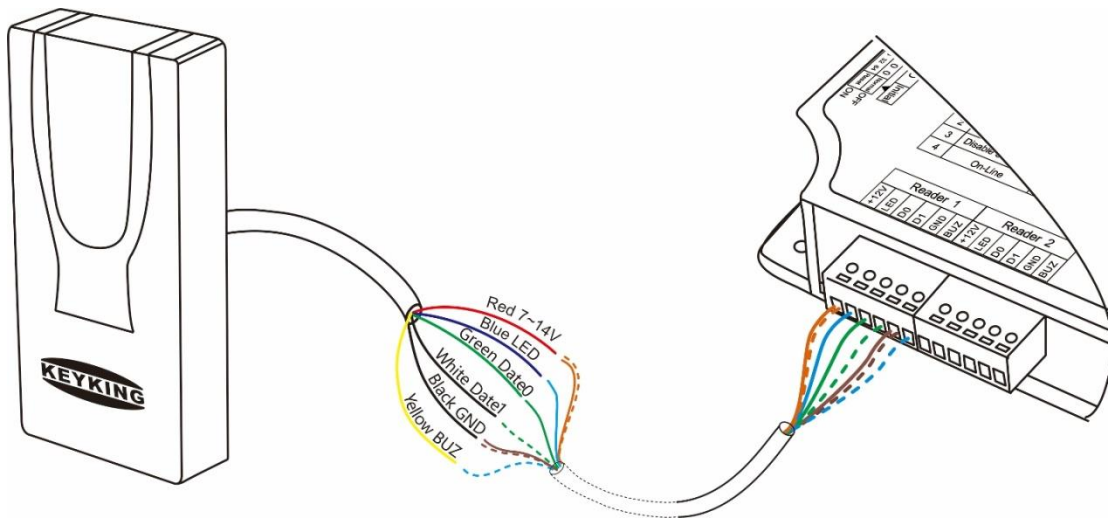

3.3.2 Reader Wiring (socket)

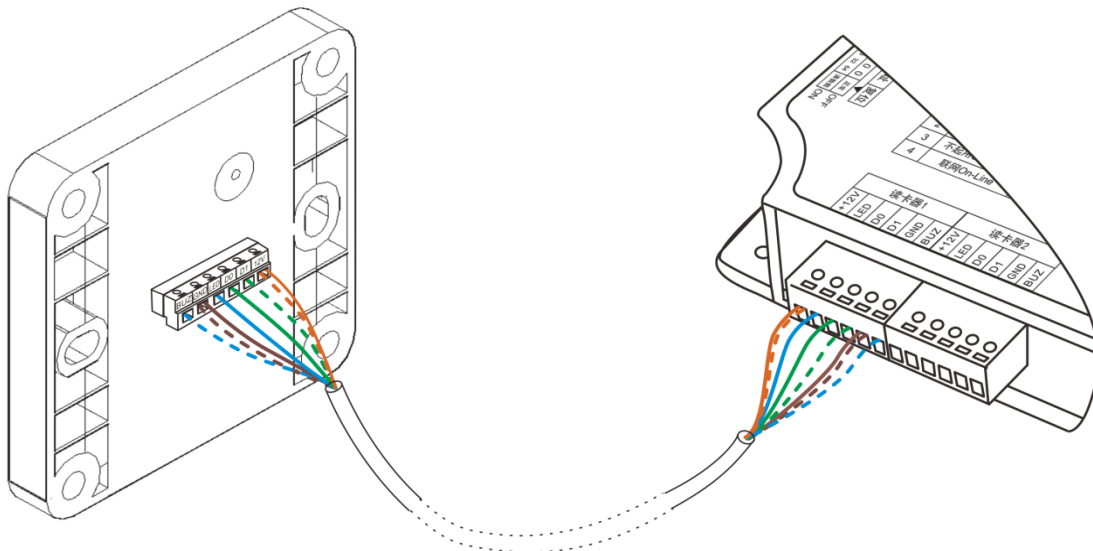

3.3.3 Attention of Reader Wiring:

- It is recommended to use CAT5E or CAT6 wires between reader and controller, the wire size is not less than 24AWG (0.206mm), normal distance is 60 meters, a maximum range of 100 meters.
- In order to ensure the reliability of data transfer, data 0 (Data0) and data 1 (Data1) must use a pair of twisted pair, such as green, green-white.
- Each reader of controller interface has a current protector Fuse, the reader current is greater than 135mA, the protector action and cut off power automatically; Reader current is less than 135mA, the protector back to normal mode. If you choose a remote reader or card

reader current requirements greater than 135mA, please do not get power directly from the card reader interface.

- In order to ensure the reliability of data transmission, please make sure that the card reader and the controller are in good condition (voltage difference is less than 0.5V). If the voltage difference between the two ground lines is too large, please double the ground wire between the two to reduce the resistance, thereby reducing the potential difference.
- If the distance between reader and controller is more than 60 meters, please use special wire CAT6 (six lines) or consult your supplier.
- The power line ends of the card reader do not connect with the ground wire, or it may burn out the card reader.

3.4 RS485 Reader Wiring

DPU3000POE series controller has RS485 card reader interface, it can connect 2N number of KEYKING-protocol RS485 reader (N= controller door number).

The power supply of the RS485 reader can be taken from the power supply side of the controller or directly from the Wiegand card reader port. However, please take care of Port Fuse current limit if the reader power is taken from the Wiegand card reader port, When the card reader is restart, the fuse is automatically protected and powered off, resulting in an illusion of system failure.

3.4.1 Controller connection

Socket	Function	RS485 Reader	
		Color	Identification
1	+12V	Red	+12V
2	GND	Black	GND
3	485+	Green	485+
4	485-	White	485-

3.4.2 485 Reader Address Setting

- The address of the RS485 reader should be set by special software. Before installation, please use the corresponding software and 485 communication converter to set the reader address and write the address on the reader label;
- The address of the RS485 reader corresponds to the label of the Wiegand reader;
- RS485 reader and Wiegand card reader can be used at the same time, card number can

be read whether from the RS485 reader or Wiegand card reader, and it will be sent to the controller to open the corresponding door if it is a valid card.

- There are two indicators of RX and TX on the controller panel to monitor the data transmission status of the RS485 reader. RX means "receive", TX means "send".

3.5 Lock Wiring

Both Fail Safe and Fail Secure locks can be used with the DPU3000POE controllers.

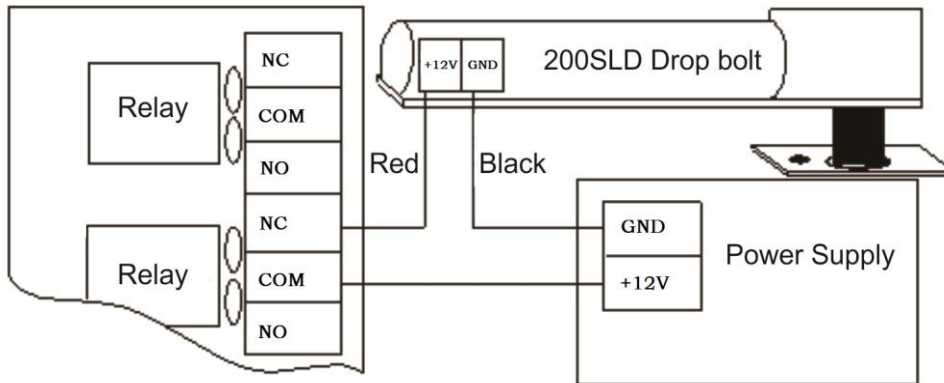

Figure 3-5-1 Drop bolt (Fail Safe)

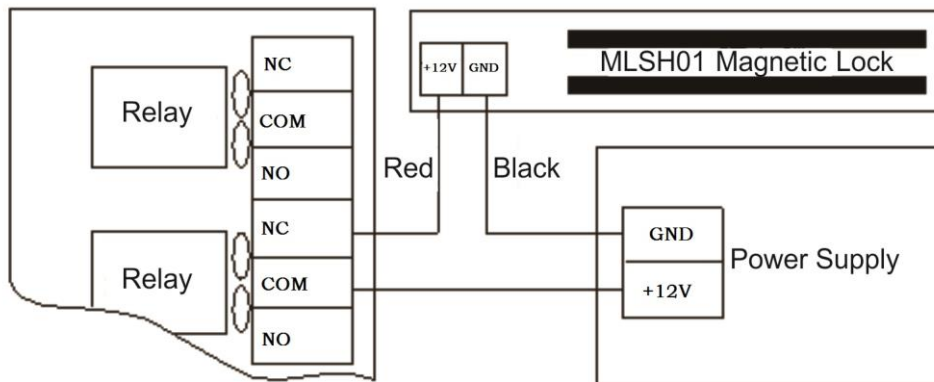

Figure 3-5-2 Magnetic Lock (Fail Safe)

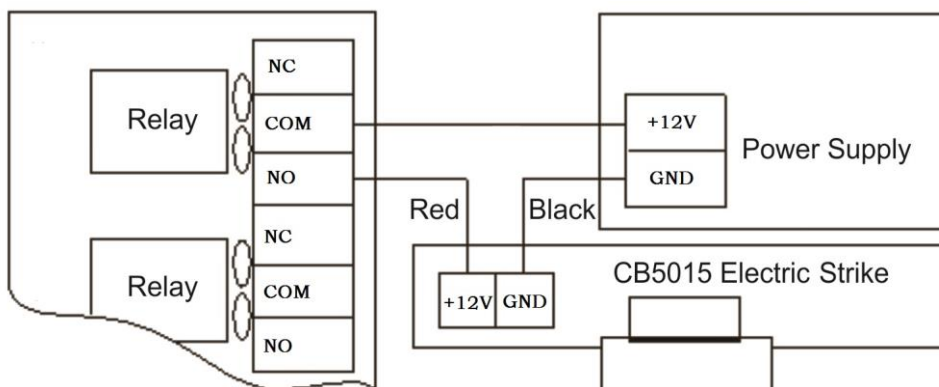

Figure 3-5-3 Strike (Fail Secure)

3.6 Sensor Wiring

Sensor Function: Reflect the switch status of the door in real time.

According to the sensor properties of normally open / close, select the corresponding value in the Sphinx4.4 – door configuration.

For example: NO-- door normally open; NC-- door normally closed.

3.6.1 The Usage of Sensor Supervisor

Sensor and aux-input point have 4 states:

- 1、 Normal = door close
- 2、 Door Open = door opened
- 3、 Short = cable shorted
- 4、 Cut = The cable is disconnected\cut off.

Attention:

- While using supervisor functions, connect two resistor like figure 3-6-1, R1=100K Ω , R2=51K Ω .
- The R1 and R2 two resistance should be installed near the door, cannot take in the vicinity of the terminal controller.
- If you don't connect R1, R2, please don't enable "Supervisor", otherwise you will often receive “controller trouble” and “controller short cut” event.

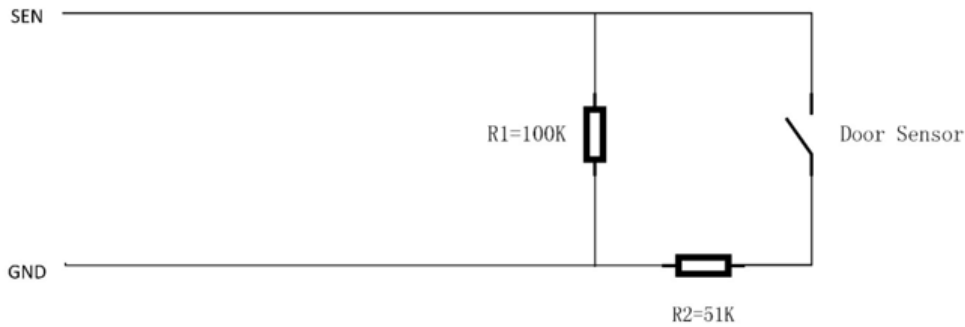

Figure 3-6-1

Short = cable shorted (figure 3-6-2) :

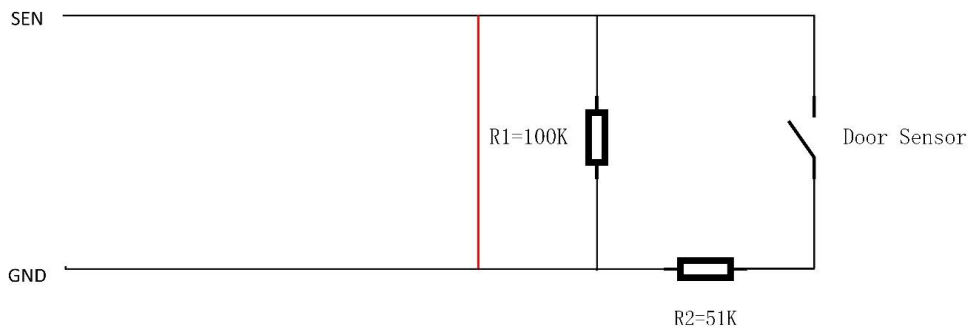

Figure 3-6-2

Cut = The cable is disconnected\cut off (Figure 3-6-3) :

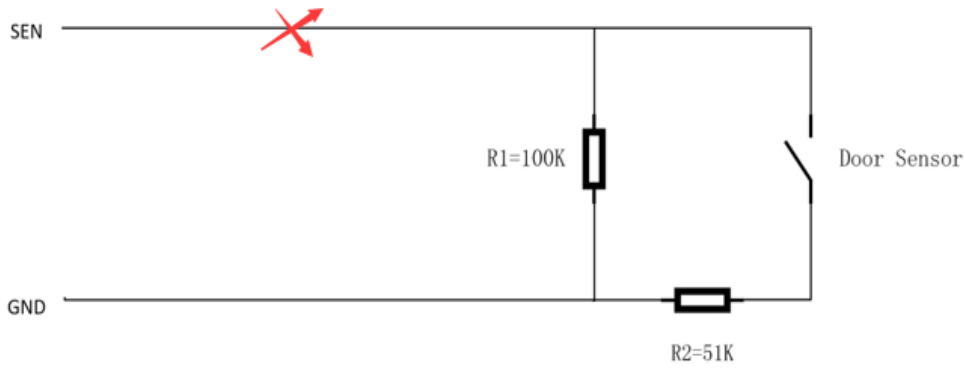

Figure 3-6-3

3.7 Controller DIP Switch

3.7.1 DIP Switch 1

S1 or Dip Switch 1 is a blue 8 way Dip Switch located at the top of the PCB. This switch is used for two functions, the controller RS485 address and for setting the initialization. When using RS485 each controller must have its own ID selected by DIP Switches S1-S7. The 1st 7 switches of Dip Switch 1 are used for setting the RS-485 ID address using Binary. When the switch is ON this means a 1, when it is OFF it means a 0. The 1st position is a 1, the 2nd a 2, the 3rd a 4, the 4th a 8, the 5th a 16, the 6th a 32 and the 7th a 64. So if all these 7 switches are on it means an address of: $1 + 2 + 4 + 8 + 16 + 32 + 64 = 127$. So the largest address is "111111" in Binary which is 127 in decimal.

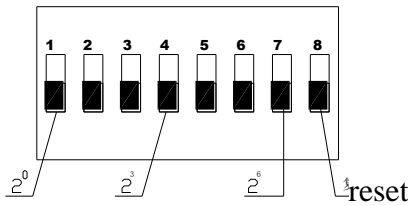

Figure 3-7-1 DIP Switch 1

DIP ID	DIP							8	
	1	2	3	4	5	6	7	Status	Reset
1	ON							ON	Reset
2		ON							Cold
3	ON	ON						OFF	Hot
.....									
127	ON	ON	ON	ON	ON	ON	ON		

Notes:

1. When using TCP communication, if the DIP switch is all OFF, physical ID = 0, at this time it is the universal address.
2. As long as the DIP switch is not all OFF, it is the actual address

3.7.2 DIP Switch 2

S2 or Dip Switch 2 is the 2nd dip switch on the controllers, The functions for Dip Switch 2 are detailed below.

DIP	OFF	ON
1	Protect	Configurable
2	Normal	Force IP: 10.1.1.10
3	Disable Supervisor	Enable Supervisor
4	On-Line	Stand-Alone

DIP 1: IP write protection. Controller all parameters can be configurable and writeable. When the dip 1 is off, Parameters including Password, IP, Host IP cannot be changed.

DIP 2: Controller works normally when dip 2 is off. When the IP address of the controller is not known, switch DIP2 to on. The IP address will default to 10.0.0.10, and the user name & password will default to system & system.

DIP 3: Enable \ Disable supervisor

DIP 4: ON--Disconnect, work as a standalone, will not connect to a PC; OFF-Connect, Enable TCP/IP.

3.8 Installation of Controller and Reader

3.8.1 Reader Installation :

Take 6630 reader as an example:



图 3-8-1

The Reader can be fixed directly to the standard 86-bottom box in the mosaic wall. First

install the reader rapping cover, and then connect the reader the line and the line of bottom box. it is best to take welding connection to ensure that the reader can be used for a long time. Package the line with a plastic wrapped, the sensor will be fixed in accordance with the instructions in place.

For the installation of other readers, please refer to their respective instructions.

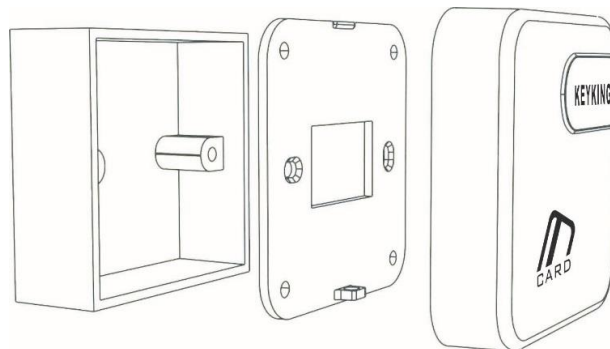
3.8.2 Controller Installation:

The access control box shall be installed in the appropriate position of several doors that can be controlled, placed on a safe or concealed ceiling, or in the control room, you are supposed tp take the controller wiring into account. The distance between the reader and the controller should not be too long. Please keep at least 100 meters. The controller box is fixed directly to the wall.

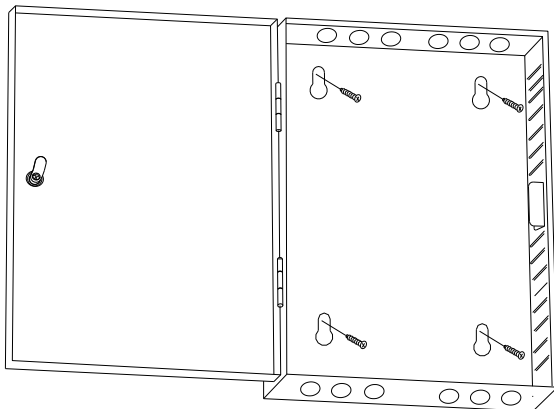

Figure 3-8-2



Figure 3-8-3

3.9 Cable Specifications

The table below lists the recommended cables for use with the DPU3000POE Series Controllers.

Use	Wiring Location	Cable Specification
Cable 1 Wiegand Reader Cable	From Wiegand reader to controller	4 pair shielded twisted pair .24AWG (0.206mm) is recommended (Belden 9841) however parallel core security cable or Cat 5 UTP will work adequately in areas of low electromagnetic interference. Maximum distance 150m (500 feet)

Cable 2 Assorted Inputs	Door sensor, REX, break glass monitoring, bond sense, tongue sense, auxiliary input	6, 8, 10 or 12 core 0.2 mm ² or 0.5 mm ² parallel core security cable or standard Cat 5 UTP. Does not normally need to be shielded unless in an area of exceptionally high electromagnetic interference
Cable 3 Lock Power Cable	From controller and power supply to locks via break glass (if fitted)	This cable depends upon distance and lock current draw. For small runs (up to 10-15m) a twin 0.75mm ² cable is normally sufficient. For longer runs a twin 1mm ² .a twin 1.5mm ² or even a twin 2.5mm ² cable could be required, not shielded.
Cable 4a RS-485 Cable	From converters to controllers and from controllers to controllers	4 pair shielded twisted pair .24AWG (0.206mm) is recommended.(Belden 9841) The maximum range is 1200m (4000 ft) Cat 5 UTP will work adequately in areas of low electromagnetic interference however a shielded cable is recommended.
Cable 4b TCP/IP Cable	From converters / controllers to a TCP/IP hub/switch	Cat 6 or above UTP. Maximum distance 100m
Cable 5 230v Power Supply Cable	From a switched 230 volt power supply source to the controller power supply	A single twin and earth 1.5mm ² or similar depending upon local regulations
Controller Earth	From the Ground terminal of the controller or power supply to a valid earth	A single core 1mm ² or similar

Twisted pair cabling is a type of wiring in which two conductors of a single circuit are twisted together for the purposes of canceling out electromagnetic interference (EMI) from external sources; for instance, electromagnetic radiation from unshielded twisted pair (UTP) cables, and crosstalk between neighboring pairs.

Twisted pair cable consists of a pair of insulated wires twisted together. It is a cable type used in telecommunication for very long time. Cable twisting helps to reduce noise pickup from outside sources and crosstalk on multi-pair cables. Twisted pair cable is good for transferring balanced differential signal.

Chapter 4 System Operation

4.1 Controller ID Setting

Disconnect the power supply before setting the address, then set the DIP switch 1-7 bit to the appropriate location, the address number cannot be repeated, otherwise it will cause 485 network communication failure.

Clear the memory RAM of the controller (if necessary). If you want to remove the RAM memory in the controller, set the SW 8 of the DIP switch to ON, By pressing the Reset button when power is on, the data in the controller RAM will be cleared.

Notes: Eliminate system RAM will completely erase all information in the DPU3000 controller and cannot be recovered.

4.2 Controller IP Configuration

Set DIP1 of SW2 to the ON position so that the IP and network parameters of the controller are configurable.

4.3 Security Check

- To ensure safety, please make sure that the ground terminal in the control box has been connected to the equipment GND of the building before the first power is delivered
- Make sure that all cables are securely connected and that they are energized.
- Cut off the power supply if the wire needs to be reconnect to avoid charging plug.

4.4 Controller Light Condition

➤ **The Power Indicator:**

The power indicator light is yellow (normally flashing every second).

➤ **TCP/IP Communication Indicator:**

LINK lights are always on, DATA lights flashing fast after communication is normal.

➤ **RS485 Communication Indicator:**

RX: Data receive indicator, red (as received data will flash fast).

TX: The data sending indicator, green (if data is being sent out, LED will flash fast).

4.5 Buzzer & LED Instructions

In order to distinguish different events, the reader will make some specific responses in daily operation,. The following table shows the response of the reader's LED indicator and buzzer to different events

Reader Parameters

LED Control Low Level ▼

Buzzer Control Low Level ▼

Buzer Alarm

- Door Opened Too Lor
- Door Forced Open
- Valid Card

Reading Delay(S) 0 ▼

Keypad Delay(S) 5 ▼

Event	Parameters	LED	Buzzer	Frequency
Invalid card	NULL	Flash 3 times	Di Di Di	2.5HZ
Invalid date or time	NULL	Flash 3 times	Di Di Di	2.5HZ
Door open unnormal	<input checked="" type="checkbox"/> Door Forced Open	Follow Buzzer	Di Di	1HZ
	<input type="checkbox"/> Door Forced Open	NONE	NONE	1HZ
DOTL	<input checked="" type="checkbox"/> Door Opened too Long	Follow Buzzer	Di Di Di	2HZ
	<input type="checkbox"/> Door Opened too Long	Normal	NONE	
Door closed	NULL	Back to Normal	Back to Normal	
Valid Card	<input checked="" type="checkbox"/> Valid Card	Follow Relay	Diiii(1s)	1HZ
	<input type="checkbox"/> Valid Card	Follow Relay	Di	

Chapter 5 Trouble Shooting

List of conventional instrument tools used to installing and diagnosing the system:

- Standard Screwdriver
- 6mm Corss Screwdriver
- Digital Multimeter
- Oblique Pliers
- Electric Iron and Solder Wire

Symptom	Possible Cause	Remedy
Yellow power LED dead	No power or low power	Check the input voltage at the terminals on the bottom of the PCB. It should be between 12V and 14VDC.
LED on reader dead	No power or low power	Check voltage at reader, it should be approximately 12v DC between red and black. Check that the total current draw from the controller is within limits.
Reader range is too short.	There is a magnetic field near the reader	Remove the item which produces the magnetic field.
	The reader cable is not shielded.	Use the shielded cable. Confirm there is at least 100mm between the reader cable and any high voltage cables.
	The reader has been mounted on a metallic surface.	Remount the reader on a non metallic surface
Cannot open the door when flashing the cards. (Check review event on PC first)	The card is invalid for the door.	Use software to enable the card for the door
	Time zone of the card is invalid.	Use software to set the user time zone to valid
	Communication problem between reader and the controller.	Check to see if the problem is caused by electromagnetic interference If so increase the distance between the reader cable and the interference or use shielded cable
	Lock problem	Check if the lock is working

		correctly
With power on, the reader goes “BEEP” but the controller cannot process the information.	Wrong connection between controller and readers.	Check the connection is correct.
	Wiegand format is not correct.	Please check your reader and card formats. As a test place all bits as 1 in the Wiegand Format Setup screen in the software for that particular bit format.
	Losing data from the controller.	Download the data again from the PC.
The controller cannot communicate with the converter.	Converter power is off.	Supply power.
	The baud rate setting is incorrect.	Set the baud rate the same as the software
	The RS-485 wires are reversed	Use the correct connections
Converter cannot communicate with PC.	The COM port setting is incorrect.	Correct the Com Port setting. Note use Windows Device Manager to find the correct comm. port.
	The RS-232 connections are reversed	Use the correct connections.
	The power supply of the converter is not sufficient.	The 9v PSU must be able to supply at least 300mA. If you use a USB cable as a PSU, please use a 2nd USB socket for the PSU or use a 12V 300mA PSU.
Some of the controllers on the RS-485 LAN cannot communicate.	Duplicate addresses	Make sure controllers have unique addresses
	The data in the RAM of the controller is corrupted.	Download the configuration again by using the software.
	RS485+ and RS485- reversed	Use the correct connections
The lock cannot be locked.	No power or low power for the lock.	Check the power supply for lock. Check that the output relay operates
The card number is different to what is expected	The reader output is set to 26 when 34 is required or the other way around	Reset reader output
Communication with the controllers intermittent	On a busy network the communication to the controllers may time out	Increase the “Network Delay Time” to 200ms
No communication with controllers	The software uses Port 8000 to communicate with the controllers. Make sure that no other software is using port 8000.	Change the Sphinx software to use another port

No communication with RS-232 or RS-485 controllers	The Desktop reader software could be using the same port as the controller communication	Check and change the Desktop reader port
--	--	--

Notes:

Please see the following functions, if the user does not know, may be considered to be faulty.

➤ **Boss Card:**

- (1) can open all the door alltime without setting access level;
- (2) door stay opened once swipe the boss card twice.;
- (3) door status back to normal when double swipe the boss card again .

➤ **Manager Card (No Anti-PassBack):**

- (1) door stay opened once swipe the card twice;
- (2) door status back to normal when double swipe the card again.

Prompt:

This manual is owned Shenzhen KEYKING Technology Co. Ltd. without the written permission of the company, no person shall have any information contained in the prospectus and the copy, copy or translated into other languages for commercial use. It is stated that as the market changes rapidly and the edition is constantly updated, this manual is for user's reference only, and is subject to physical packing. If any changes are made without prior notice, the company reserves the right to final interpretation!